



100 Blake Road, Denver, IA 50622
 Ph. (319)984-9298, Fax (319)984-9299
www.twistgear.net

SportGear

For Sportster & Buell Motorcycle Transmissions

Model Year	Output Shaft	Counter Shaft	5th Gear Ratio	Trans Sprkt	Belt Drive Sprkt	Final Drive Ratio	Rear Belt	Sprkt Ctr Dist
1994 1/2 - up Buell & 883	42	25	1.68	27	61	2.26	128T	583mm
1994 1/2 - up Sportster1200	42	25	1.68	29	61	2.10	128T	577mm
1989-1994 Sportster 883	33	19	1.74	27	61	2.26	128T	583mm
1989-1994 Sportster 1200	33	19	1.74	29	61	2.10	128T	577mm
1989 - up SportGear	42	22	1.91	29	55	1.90	125T	578mm

What happens if SportGear is installed in my 1994-up Sportster/Buell?

SportGear provides 13.6% more gear reduction. Using the 55/29 sprockets reduces engine rpm's 16.1% in 5th gear, yet only 4.6% in 1st – 4th gears.

Translated, this means that engine speeds drop a whole lot in 5th gear, but very little in the first four gears. The bike now has taller gears. This creates the same affect as an overdrive transmission, yet it retains all the benefits of a direct drive and at a fraction of the cost.

What happens if SportGear is installed in my 1989-1993 Sportster?

SportGear provides 9.9% more gear reduction. The 55/29 sprockets reduce engine rpm's 9.8% in 5th gear. Also, 1st – 4th gears go 0.9% faster. This means that engine rpm's are reduced 10% in 5th, yet the first four gears remain practically unchanged.

Does SportGear affect Sportster engine vibration?

Sportsters rigidly mount the engine to the frame. When the 55/29 sprockets are installed along with SportGear, the engine speed is reduced about 250 rpm at 60 mph, resulting in less engine vibration and more comfortable riding.

How about highway cruising on my Buell?

The 55/29 sprockets reduce engine speed about 470 rpm at 60 mph in 5th gear. SportGear increases the gear reduction to keep 1st-4th gears close to the original engine rpm's so performance is not significantly affected in the first four gears. This provides 4 narrow ratio speeds for street performance, with a large step to a highway cruising gear.

How does SportGear affect my Buell at the track?

With the 55/29 sprockets installed, your top end speed can be increased about 30 mph before hitting the engine rev limiter. With the 55/27 sprockets installed, acceleration is increased 5.8% in the first four gears, and top end speed is increased 6.9% in 5th gear.

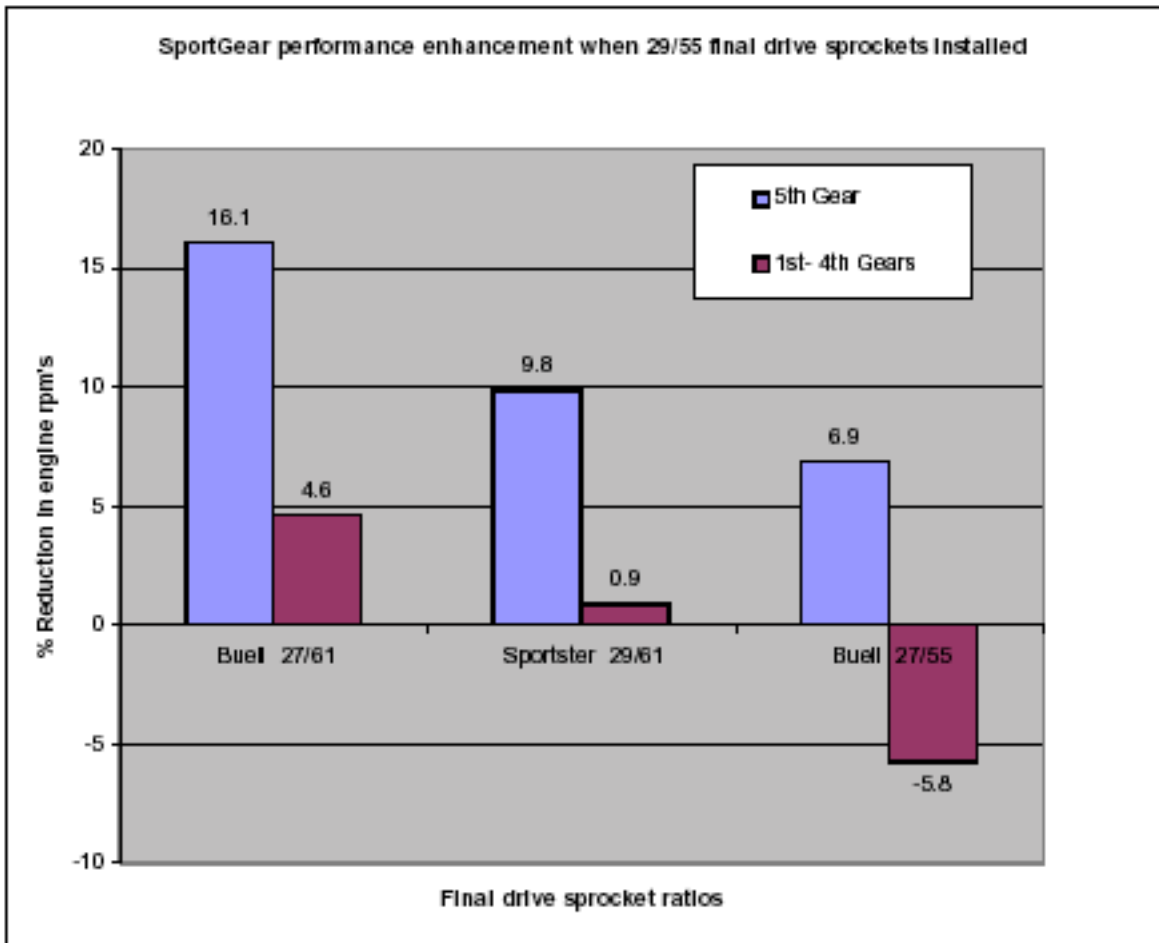

Performance Features:

- 1) Belt life is increased when the 29T drive sprocket is installed instead of the 27T sprocket due to the larger bend radius and reduced belt tension.
- 2) The trap door bearing retention system on the counter shaft has been improved to prevent screw loosening. This is especially important when retaining helical gears, since the axial forces work the joint.
- 3) Good joint designs require sufficient fastener stretch so the screws don't vibrate loose. Long 2" grade 8 hex screws (see figure 1) provide the necessary stretch and strength. Assemble the screw with thread locker or loctite on the threads as added insurance against screw loosening.
- 4) The output shaft has been lengthened to include a retainer ring (see figure 1), which keeps both the oil seal from falling out of the bore (a common problem with OEM other aftermarket parts), and also prevents the shell bearing from moving out of the bore.
- 5) The counter shaft gear is located more accurately with the one piece design.

Gear data comparison: helix angle, stress, contact ratio, stress, noise

	SportGear 42/22	Stock 42/25
Profile contact ratio	1.4	2.0
Face contact ratio	1.0	0
Total contact ratio	2.4	2.0
Pressure angle	29°	20°
Gear rim thickness	no rim	0.29"

Assembly

Two thrust washers are required at the position shown by the arrow in figure 2.
One washer is included in the kit.

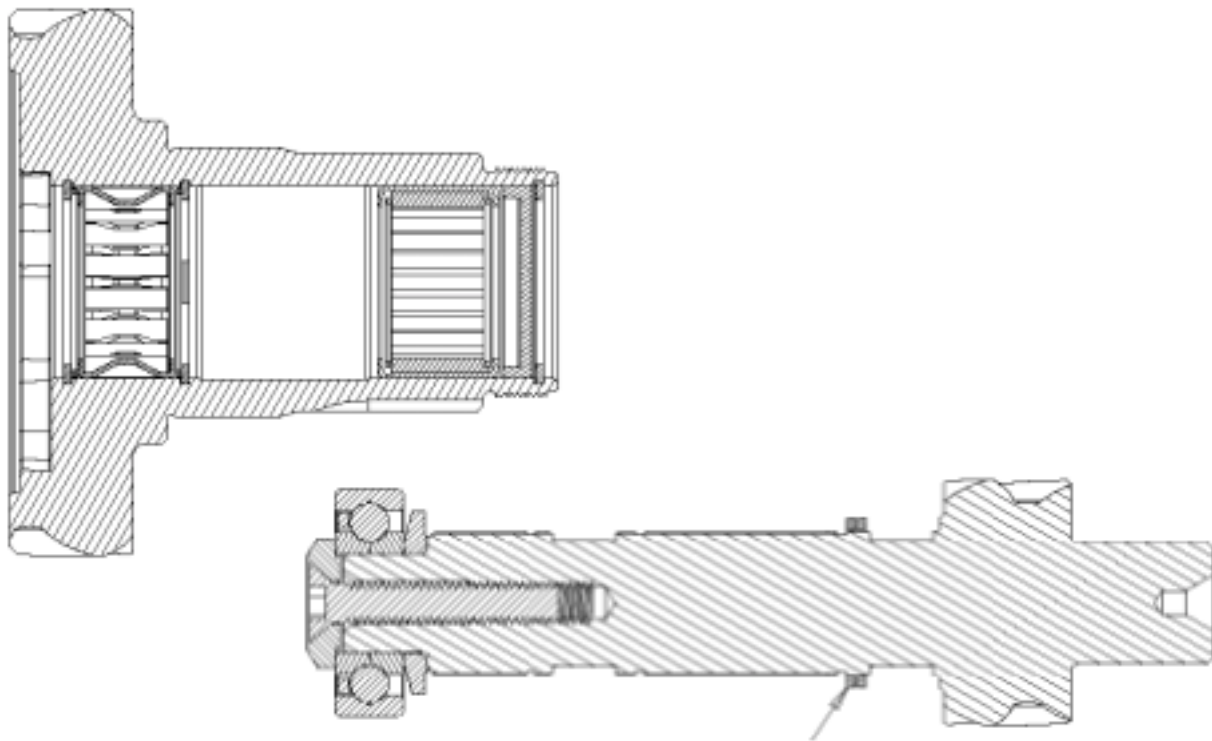

OEM Stock Items	OEM p/n
Transmission sprocket, 27T	40288-95
Transmission sprocket, 29T	40205-95
Sprocket, Belt Drive, 55T	37727-97Y
Sprocket, Belt Drive, 61T, black.....	40213-00
Sprocket, Belt Drive, 61T, silver	40227-00
Rear Belt, 125T	40038-91
Rear Belt, 128T	40022-91

Sprockets and belt are not included in the kit.